

**PACIFIC
SUPPORT
EQUIPMENT**



Ours is a World of
Quality, Integrity,
Commitment,
and Pride.

INTRODUCTION TO THE COMPANY

Pacific Support Equipment Ltd. (PSE) established in 1987 specializes in the manufacture of high quality Aero Engine Tooling, Industrial Gas Turbine Tooling, and Aircraft Ground Support Equipment, including our own proprietary line of Aircraft Towbars.

We have an excellent reputation for supplying high quality products on time and at a competitive cost. We have the ability to design and manufacture to the customer needs as well as being able to modify or refurbish existing equipment. We stand behind all of our manufactured products and offer complete after sales service.

Quality is a priority for all of our products. Our quality assurance program ensures consistent, accurate production during all of our manufacturing operations. Our certified proof load testing facility guarantees reliability of all of our load lifting and handling tools.

PRODUCT CATEGORIES

Our Ground Support Equipment products fall into four main categories:

1. Aircraft Towbars
2. Aero Engine Maintenance Tooling
3. Aircraft Hanger Equipment
4. Special Purpose Tooling & Equipment

CONTACT INFORMATION

Pacific Support Equipment Ltd.
#15 – 12491 No. 2 Road
Richmond, B.C.
Canada
V7E 2G3

Phone: (604) 275-9131

Fax: (604) 275-0548

Website: www.pacificsupportltd.com

Email: pseltd@pacificsupportltd.com

ENGINE SHOP TOOLING



We at PSE realize that Aero/Industrial Engine Overhaul and Shop Tooling are quite specialized. The engine manufacturers themselves normally stipulate tooling requirements. However, PSE is capable of answering that need. If you have a tooling requirement and you can supply the drawings or specifications, we can manufacture it for you.



We have manufactured turbine engine overhaul tooling since 1987. We have manufactured tooling to support GE Engines, CFM Engines, Pratt & Whitney Engines, Allison, and Rolls Royce Engines for our various customers. We also have the capability of designing and building tooling that is unique to specific customer requirements.

Our capabilities don't only include building new tooling but we have the capability to refurbish used tooling too. If you have a tool, stand, lift beam, etc. that you feel can be refurbished, we probably would be able to refurbish it for you.





Our machine shop equipped with CNC and conventional milling machines, lathes, and surface grinder along with our skilled workforce can tackle almost any tooling requirement. Also, our fabrication shop has the capabilities to fabricate any material. Together we can address almost any requirement you may have.

Our experience and reputation in the industry has proven PSE can provide high quality tools at reasonable costs. Furthermore, we have proven to our customers our reliability to support their requirements. Reliability and customer satisfaction has built PSE to what it is today. The following are a number of tools that PSE has designed and built through the years.

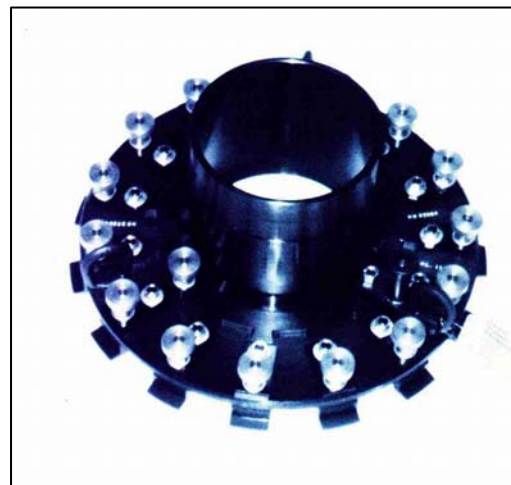

ENGINE SHOP TOOLING

PSE 257 Dehaviland 8 Prop Balancing Fixture

This fixture is one of many developed by PSE for the corporate aircraft servicing groups. It is used to verify and adjust the balance of the high speed propellers prior to installation within the balance limits specified.



PSE 340 JT8 Exhaust Nozzle Inst/Rem Dolly

This unit was developed for use in the engine test cell to attach the heavy-duty exhaust test nozzle to the rear of the engine. It features variable height and rotational adjustments.



PSE 342 CF6-HPC Core Transport Stand

This dolly is used to move the assembled core of the engine in a vertical configuration from station to station. It incorporates heavy duty "easy roll" casters, swivel towbar, and a webbing restraint harness.

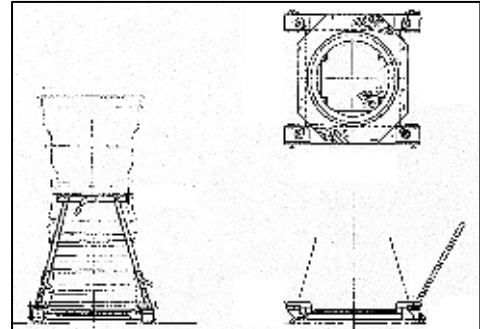

PSE 350 JT8 Diffuser Case Rollover Workstand

This rotational workstand is used for gaining access to all parts of the diffuser case during inspection and maintenance work. It has an anti rollback gearbox with safety lock pins for all angles.

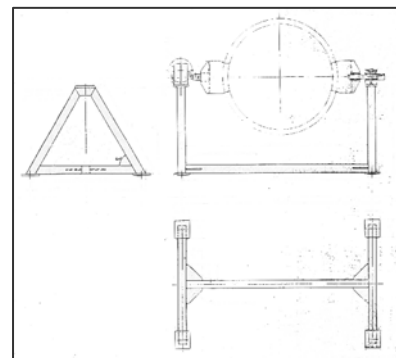

PSE 352 CFM 56 Test Cell Adapter Lift Beam

This motorized variable C of G lift beam rated at 20,000 lbs. is used to move the completely assembled engine, the engine test-mounting adapter, complete with test nozzles, into the running position in the test cell.

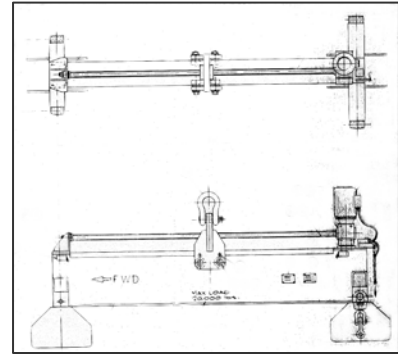

PSE 354 CFM 56 Test Cell Bellmouth Lift Sling

This special purpose lift sling is typical of many of the special purpose slings developed to lift and install components with off center weights and configurations. It incorporates turnbuckle adjustment and variable pick up points. Manufactured, proof loaded, and certified by PSE.

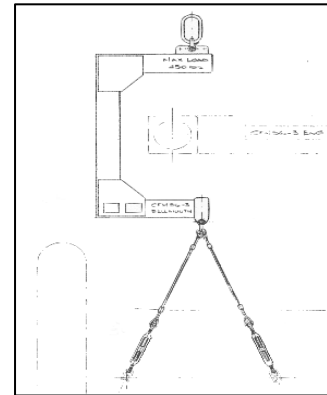

PSE 365 JT8 Intercase Rollover Workstand

This rollover workstand is used for holding this section of the engine while inspection and maintenance procedures are carried out. The anti roll gearbox and safety locking pins ensure stability in all positions.

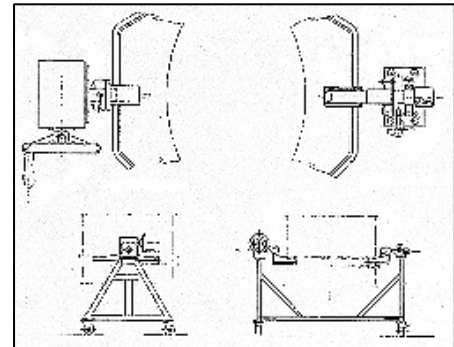

PSE 425 LM6000 Engine Transporter

This transporter has been designed and built with proper shock and vibration dampeners. It has also been designed with adaptable mounting for all versions of the LM6000 industrial turbine engine. It is built with tie-downs, engine adapters for the fore- and aft- engine mounts, and a storage box. It is designed for air ride truck transport and/or air cargo transportation on a B747 cargo aircraft.



PSE 430 Avon Engine Cradle

This Cradle has container tops to protect the engine during transportation. The container tops seals and protects the Avon engine from any contamination. It also has built-in shock and vibration dampeners to prevent damage to the engine during transportation.



PSE 431 Low Profile Engine Bootstrap - Aft

This is a special design bootstrap with a low profile to replace the standard aft bootstrap. It allows the bootstrap to be utilized with different versions of the A310 Engines. It gives more clearance to the engine components and therefore allows for faster engine changes without pre-disassembly of other components. Manufactured, proof loaded, and certified by PSE.



PSE 463 CFM56 Fan Frame Dolly

This dolly was designed to assist maintenance of the engine fan frame by allowing the frame to be mobile in the maintenance shop. It is equipped with the same engine mounts and adapters that the standard pedestals have. It is adjustable for easy mounting of the fan frame and designed for easy loading onto the dolly. The dolly is forkliftable and mounted with casters and floor locks.

